

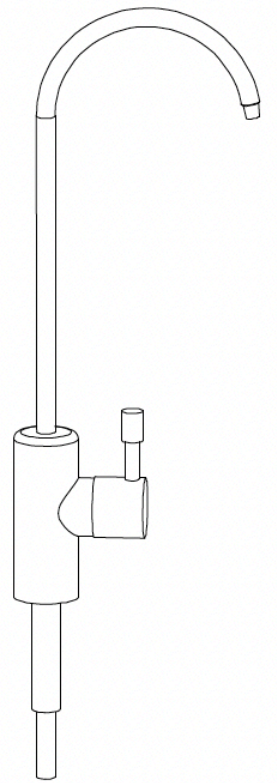

WATER  
TREATMENT  
AT HOME

SPECTRUM  
HOME

Z1 PURE RO SYSTEM MANUAL

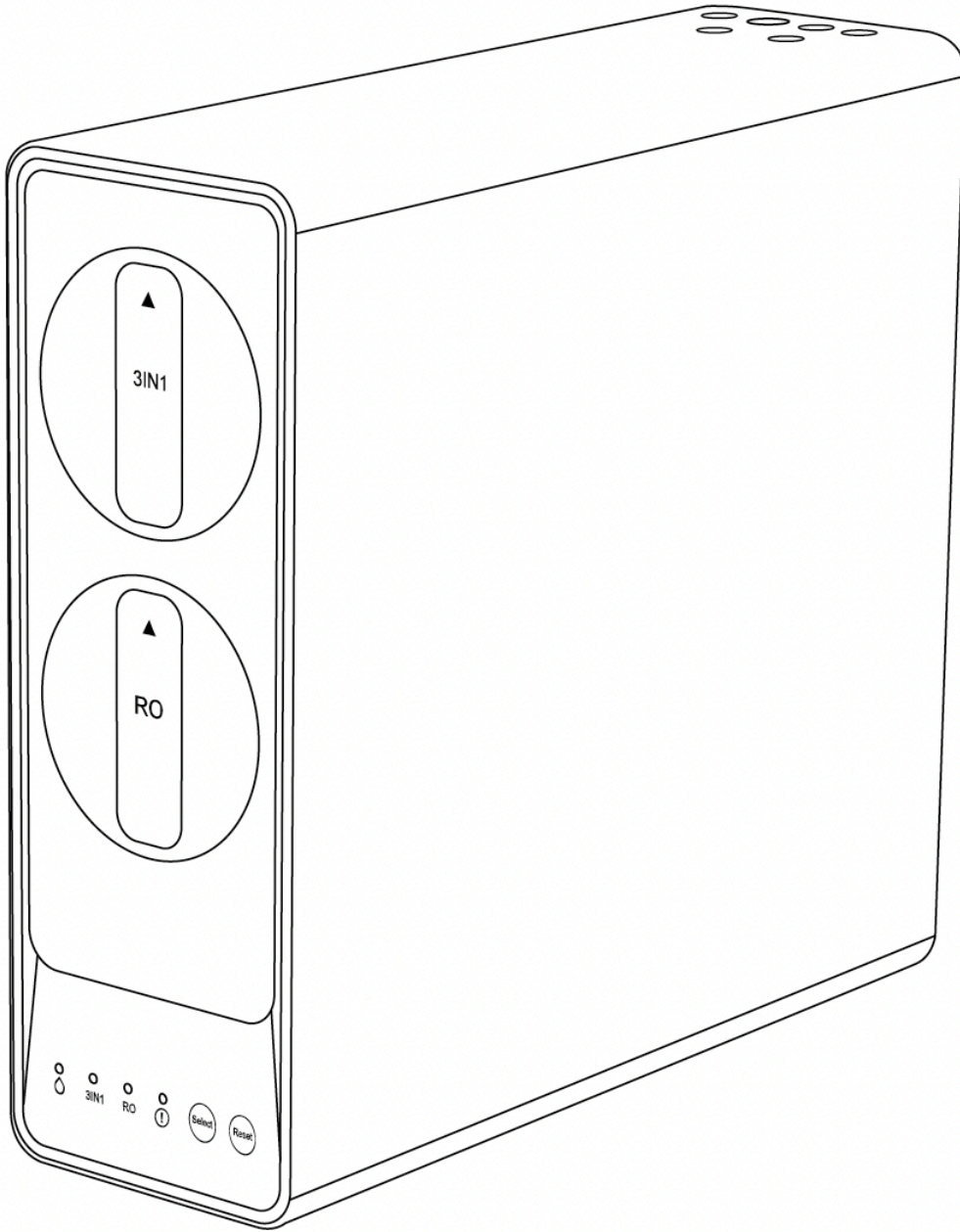

# CONTENTS

<b>BEFORE INSTALLING</b>	<b>4</b>
<b>RO SYSTEM SPECIFICATIONS</b>	<b>5</b>
<b>UNPACK &amp; INSPECT YOUR RO SYSTEM</b>	<b>7</b>
<b>RO SYSTEM DIMENSIONS</b>	<b>8</b>
<b>OVERVIEW OF THE RO SYSTEM'S COMPONENTS</b>	<b>9</b>
<b>FLOW DIAGRAM</b>	<b>10</b>
<b>ELECTRICAL SCHEMATIC</b>	<b>10</b>
<b>PARTS BREAKDOWN</b>	<b>11</b>
<b>INSTALLATION</b>	<b>12</b>
<b>LED DISPLAY &amp; TOUCH KEYS PROGRAMMING GUIDE</b>	<b>18</b>
<b>SERVICE AND MAINTENANCE</b>	<b>20</b>
<b>TROUBLESHOOTING GUIDE</b>	<b>22</b>

- Please read carefully before proceeding with installation. Your failure to follow any attached instructions or operating parameters may lead to the product's failure. Keep this manual for future reference.
- Do not use the water that is microbiologically unsafe or of unknown quality without adequate disinfection before or after the system.
- Test the water periodically to verify that the system is performing satisfactorily.

- You must read and understand the contents of this manual before installing or operating your RO system.
- The Z1 has a 1-year warranty from the date of sale.

*Personal injury or property damage could result if you fail to follow instructions in this manual.*

- This system and its installation must comply with state and local regulations. Check with your local public works department for plumbing and sanitation codes. Local codes should be followed in the event the codes conflict with any content in this manual.
- This RO system must be operated on pressures between 1 bar to 4 bar. If the water pressure is higher than 4 bar, use a pressure reducing valve in the water supply line to the RO system.
- This unit must be operated at temperatures between 5°C - 38°C (41°F and 110°F).
- Do not use this RO system on hot water supplies.
- Do not install this unit where it may be exposed to weather, direct sunlight, or temperatures outside of the range specified above.
- The appliance is only to be used with the power supply unit provided with the appliance.
- The appliance must only be supplied at safety extra low voltage corresponding to the marking on the appliance.
- Do not use water that is microbiologically unsafe without adequate disinfection before or after this system.
- This publication is based on information available when approved for printing. Continuing design refinement could cause changes that may not be included in this publication.
- Children should not play with the appliance.

## INSTALLATION NOTES & SAFETY MESSAGES

Look for the following messages in this manual:

### Example

#### NOTE

Follow all National and Local Authority Codes and Regulations governing the installation of plumbing devices.

### Example

#### CAUTION

Disassembly while under pressure can result in flooding.

### Example



#### CAUTION

**Electrical Shock Hazard!** Unplug the unit before removing the cover or accessing any internal control parts.

<b>Model</b>		Z1
<b>Water Supply</b>		Municipal Water
<b>Feed Line Pressure</b>		1 - 4 bar
<b>Product Flow</b>		2 lpm
<b>Salt Rejection</b>		≥93%
<b>Recovery</b>		≥65%
<b>Feed Water Temperature</b>		5 ~ 38°C
<b>Sound Level</b>		≤60dB
<b>Electrical</b>	<b>Input</b>	100 ~ 240V AC 50/60Hz 3A
	<b>Output</b>	DC24V 5A
	<b>Power Used</b>	120W
<b>Membrane</b>	<b>Type</b>	Thin Film Composite Membrane
	<b>Rating</b>	3000 lpd
<b>Connection</b>	<b>RO</b>	1/4" Quick Connect
	<b>Inlet</b>	3/8" Quick Connect
	<b>Drain</b>	1/4" Quick Connect
	<b>Power</b>	Quick Connect Power Cable
<b>Accessory</b>		Tap & Installation Kit Included
<b>Gross Weight</b>		15 kg
<b>Product Dimension (W x D x H)</b>		130 x 397 x 376mm
<b>Carton Dimensions (W x D x H)</b>		358 x 476 x 440mm

• Salt rejection and product flow are variable and can be effected by temperature and feed water conditions.

Model	Stage 1	Stage 2	Stage 3	Stage 4	Tap
Z1	Sediment Filter	Pre Carbon Block Filter	Reverse Osmosis Membrane	Post Carbon Block Filter	SS Steel
	Z1-C	Z1-C	Z1-M	Z1-C	

The performance of the Z1 system can be characterised and judged by the quality of the water produced by the system. By measuring the contaminant removal performance and flow rates of the system, its operating status can be easily evaluated.

### **FACTORS WHICH AFFECT PERFORMANCE**

Performance of the reverse osmosis membrane is affected by several factors which must be considered when judging the condition of the system. The main factors which affect system performance are pressure, temperature, total dissolved solids (TDS) level, recovery and pH.

#### **PRESSURE**

Water pressure affects both the quantity and quality of the water produced by the RO membrane. Generally, the more water pressure, the better the performance of the system.

#### **TEMPERATURE**

The reverse osmosis process slows with decreasing temperature. To compensate, a temperature correction factor is used to adjust the actual performance of the RO membrane filter to the standard temperature of 77°F (25°C). This allows the performance of the unit to be accurately gauged against published standards. Temperature does not affect the concentrate flow rate.

#### **TOTAL DISSOLVED SOLIDS**

The minimum driving force which is necessary to stop or reverse the natural osmosis process is termed osmotic pressure. As the total dissolved solids level of the feed water increases, the amount of osmotic pressure increases and acts as back pressure against the reverse osmosis process. Osmotic pressure becomes significant at TDS levels above 500 mg/L(ppm).

#### **HARDNESS**

Hardness is the most common membrane foulant. If ignored, this relatively harmless component of feed water will scale a membrane over time. Use of a softener will reduce the fouling effect on a membrane. One way to detect too much hardness in the feed water is the weight of a membrane installed for a period of time. A fouled membrane (dried) will weigh significantly more than a new membrane. The increase in weight is a result of precipitated hardness inside the membrane.

#### **IRON**

Iron is another common membrane foulant. There are a variety of types of iron, some of which cannot be removed by an iron filter. Clear water iron can be removed more effectively by a softener. Particulate iron can be removed more effectively by a 1 micron filter. Organic bound iron can be removed only by activated carbon or macroporous anion resin. If there is enough iron to exceed the drinking water standard and softening the water is not an option and the iron is soluble, then an iron filter is appropriate. If none of these are an option, then regular replacement of membranes will have to be accepted.

#### **PRODUCT WATER RECOVERY**

Product water recovery plays an important role in determining membrane and system performance. Recovery refers to the amount of water produced in relation to the amount of water sent to drain.

The standard calculation is: % Recovery =  $\text{Product Water} \div (\text{Product Water} + \text{Waste Water}) \times 100$

The system uses a flow control assembly to restrict the flow of waste water to the drain. This restriction helps maintain pressure against the membrane. The sizing of the flow control assembly determines the recovery rating of the system. The system is manufactured with a recovery rating designed to be more than 50%. Depending on temperature, pressure and tolerances, the actual recovery value may be slightly different for each system.

## UNPACK & INSPECT YOUR RO SYSTEM

Inspect the RO system for any shipping damage. If damage is found, notify the transportation company and request a damage inspection. Damage to cartons should also be noted.

Handle all components of the system with care. Do not drop, drag or turn components upside down.

The manufacturer is not responsible for damages in transit. Small parts, needed to install the RO system, are in a parts box. To avoid loss the small parts, keep them in the parts bag until you are ready to install.

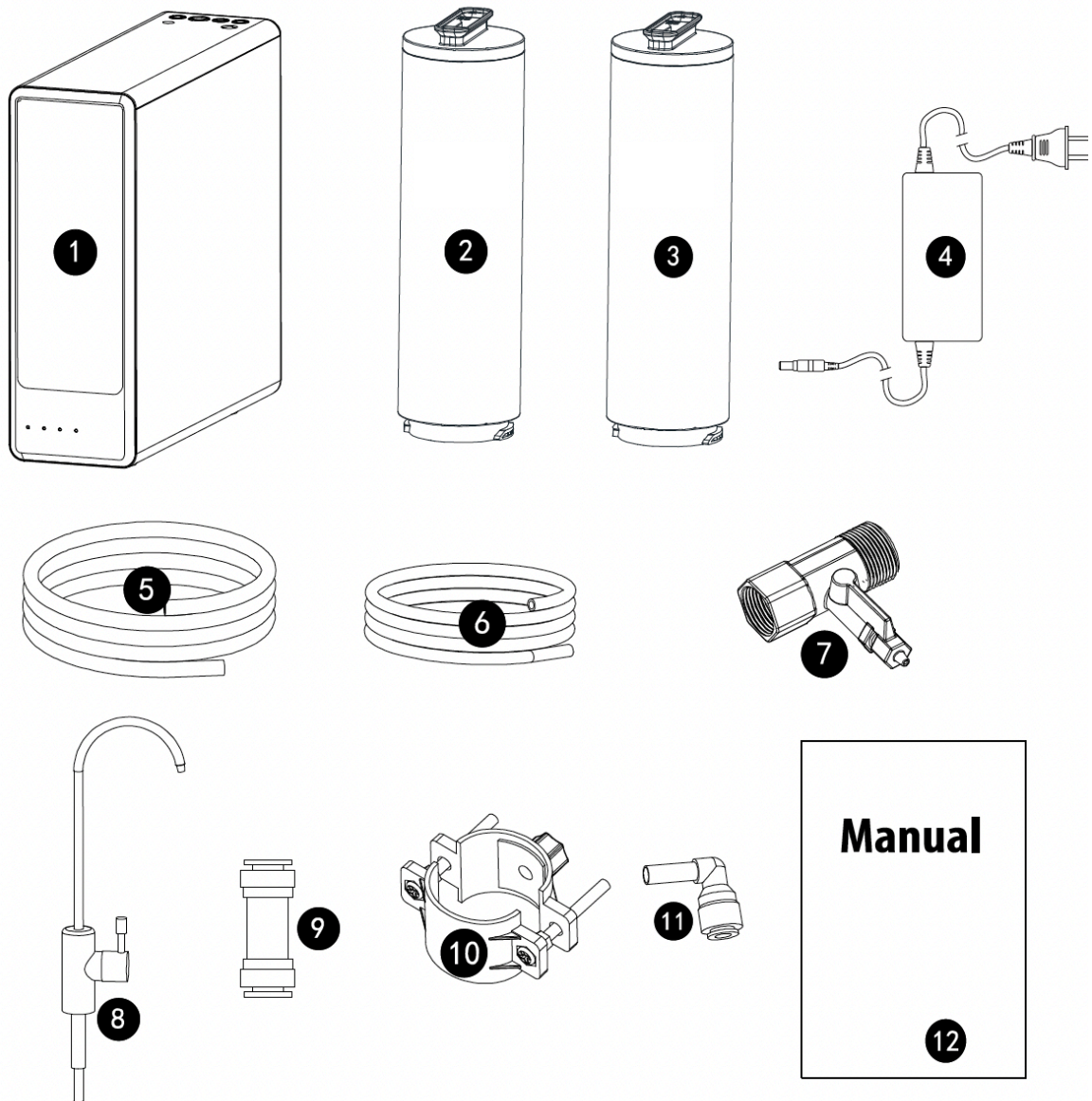

1. RO Module Assembly x 1

2. Z1-C 3-in-1 Filter Cartridge x 1

3. Z1-M RO Filter Cartridge x 1

4. Power Transformer x 1

5. 3/8" Tubing x 1

6. 1/4" Tubing x 1

7. Inlet 3-Way Valve (1/2") x1

8. SS Mini Tap x 1

9. Tap QC Connector (1/4") x1

10. Drain Saddle x 1

11. Drain Saddle Connector (1/4") x1

12. User Manual x 1

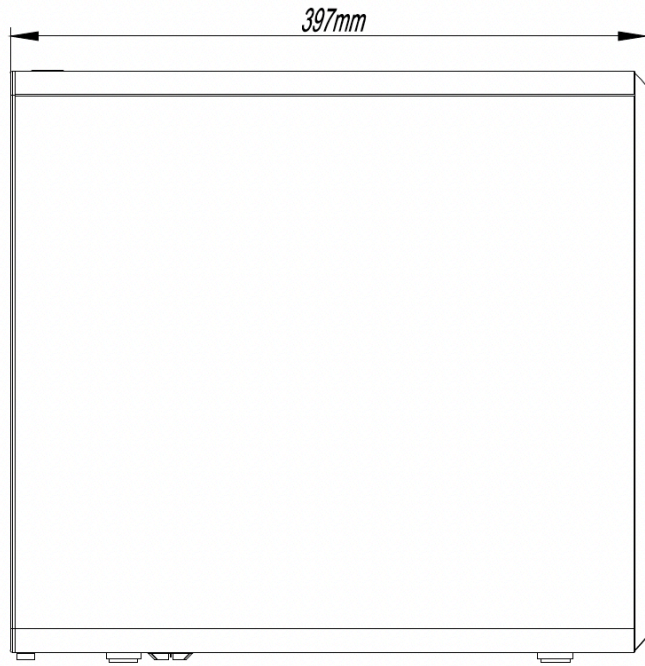
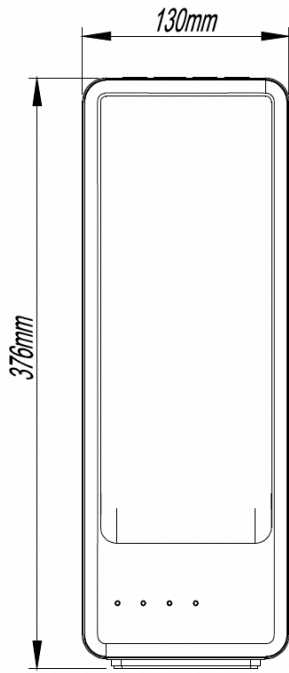

## OVERVIEW OF THE RO SYSTEM'S COMPONENTS

### 1. RO Manifold Assembly

The manifold assembly serves as the functional hub of the RO system by directing the flow through each of the main components.

### 2. Booster Pump

The booster pump built inside the manifold assembly improves the production rate and reduction of dissolved substances from water. It has a rated continuous run time of 60 minutes.

### 3. Automatic Solenoid Valve

The automatic solenoid valves are controlled by the program settings, it is used to control the water flow ON&OFF.

### 4. Low Pressure Switch

The low pressure switch ensures the boost pump runs safely. It will shut off the power to avoid the boost pump "running dry" if feed water pressure is less than 0.5 bar (7 psi).

### 5. High Pressure Switch

As the tap is closed, the high pressure switch will shut off the power to stop running the boost pump.

### 6. 3 in 1 Filter

The 3-in-1 filter assembly (Z1-C) utilises well designed water flow structure to integrate particulate filtration, pre carbon filter and post carbon filter into one filter cartridge. The sediment filter screens out particulate material, such as dirt, sand, or rust, which may clog the other filters in the system. The pre carbon filter reduces chlorine which may damage the RO membrane filter. It must be regularly checked and/or replaced to prevent premature membrane failure and poor water quality. The post carbon filter adsorbs any residual tastes and odours just before the water is delivered through the tap.

### 7. Reverse Osmosis Membrane

The RO membrane (Z1-M) reduces dissolved substances and other microscopic impurities. It consists of a membrane envelope wound around a perforated tube. Product water diffuses through the membrane to the inside of the envelope where it flows to and is collected by the tube. Impurities are flushed away in the drain stream. The RO membrane featured in the Z1 system offers exceptional contaminant rejection, application versatility and long life. The membrane material is sensitive to an attack by chlorine.

The activated carbon filter must be maintained properly to prevent premature failure of the RO membrane.

### 8. Tap

The tap allows the product water to be drawn from the system with a simple rotation of the handle.

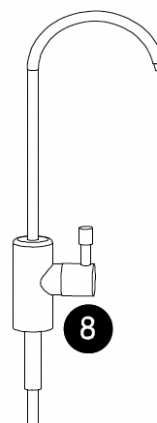
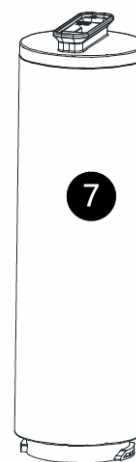
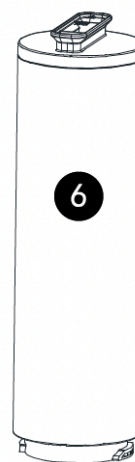
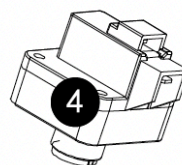
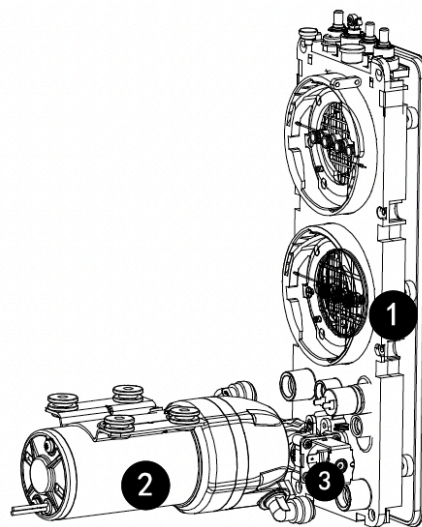

FLOW DIAGRAM

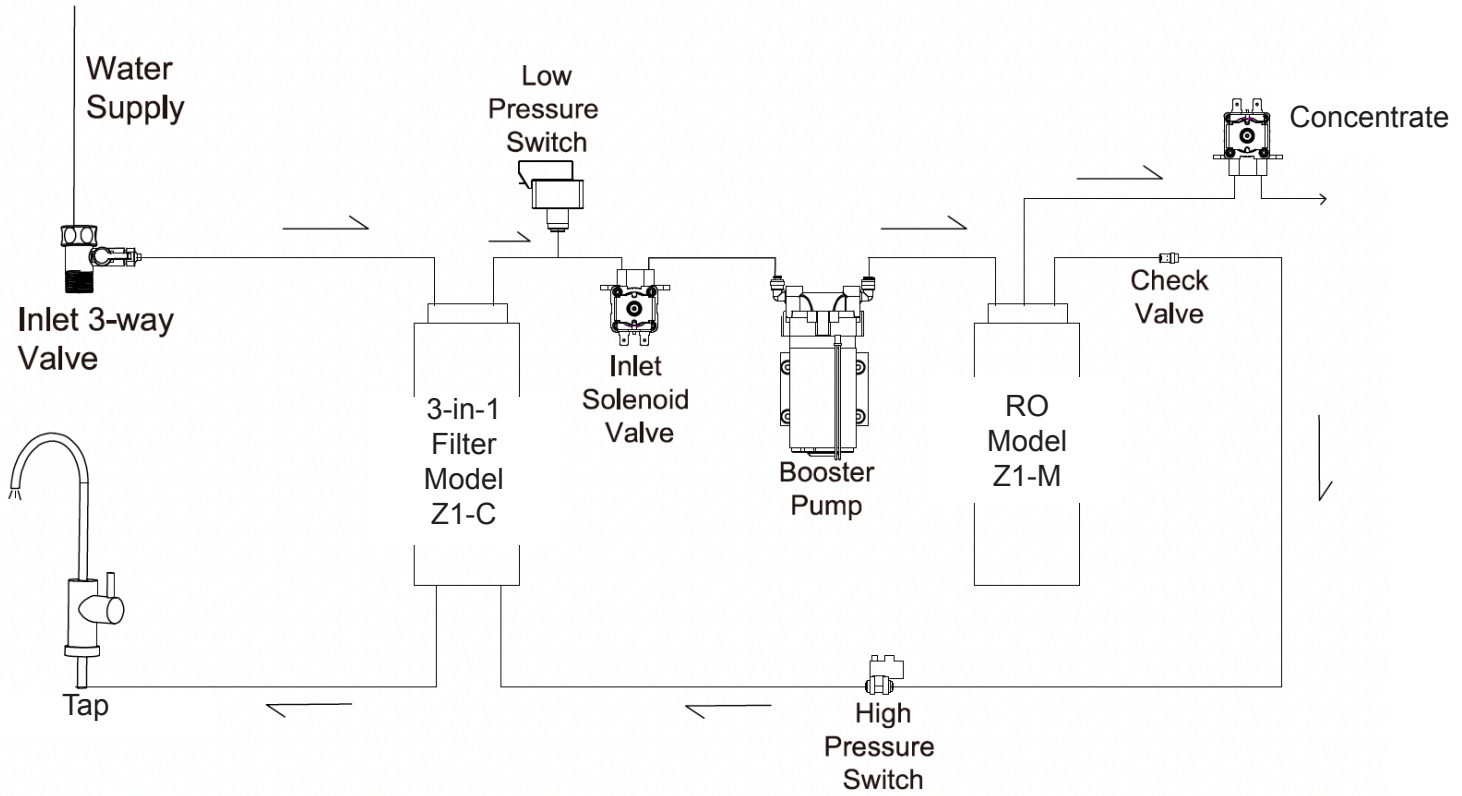

ELECTRICAL SCHEMATIC

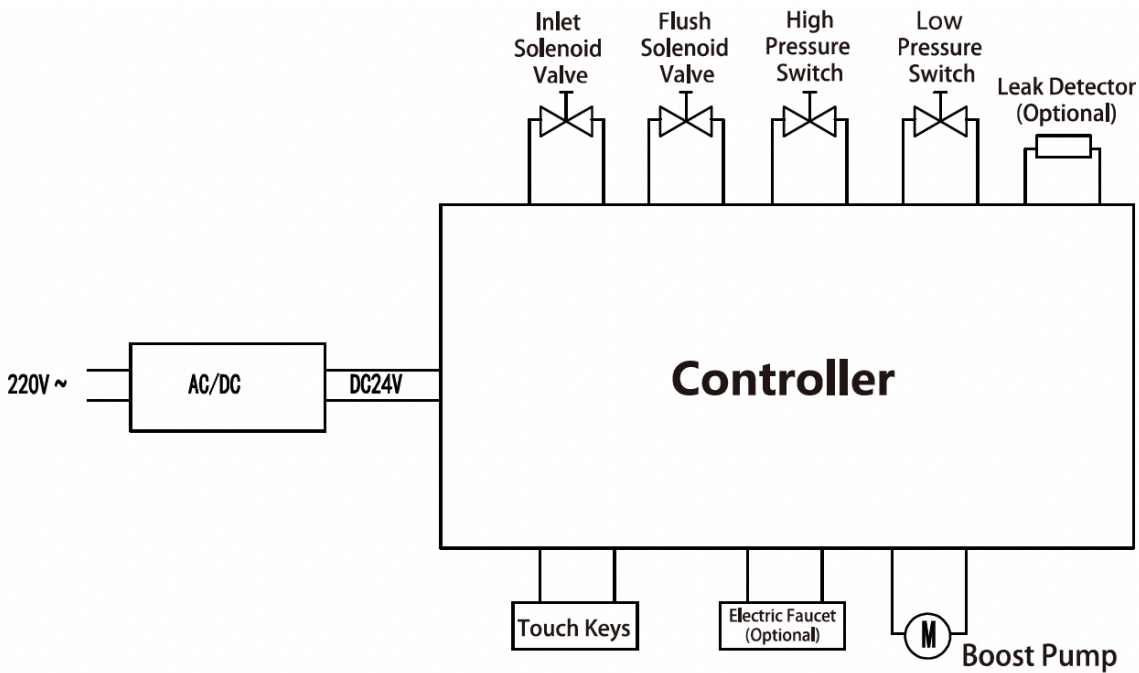

PARTS BREAKDOWN

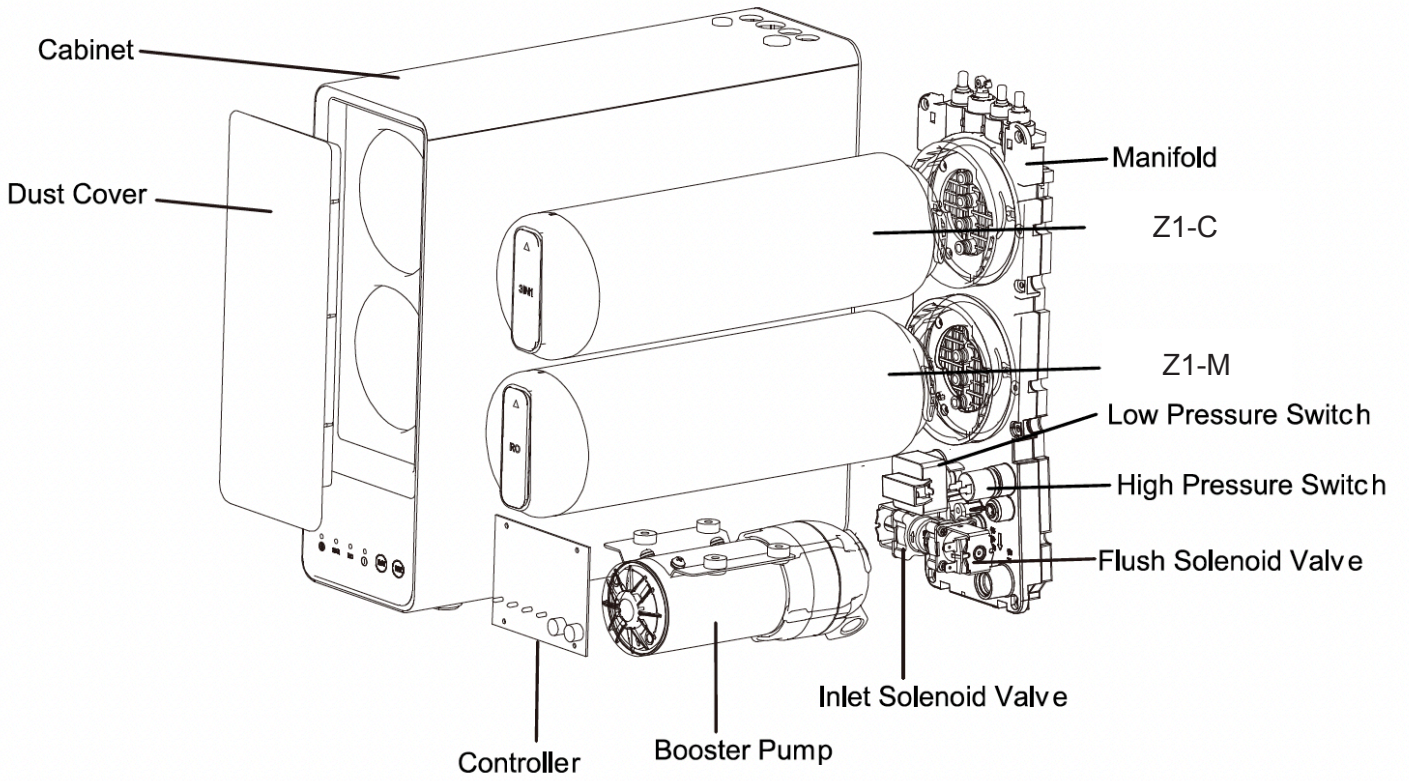

## BEFORE INSTALLATION

1. Check the accessories in the packing box and confirm if they are complete.
2. Shut off the water supply before installation.
3. Prepare some tools or equipment required for installation.

## SUGGESTED INSTALLATION EQUIPMENT

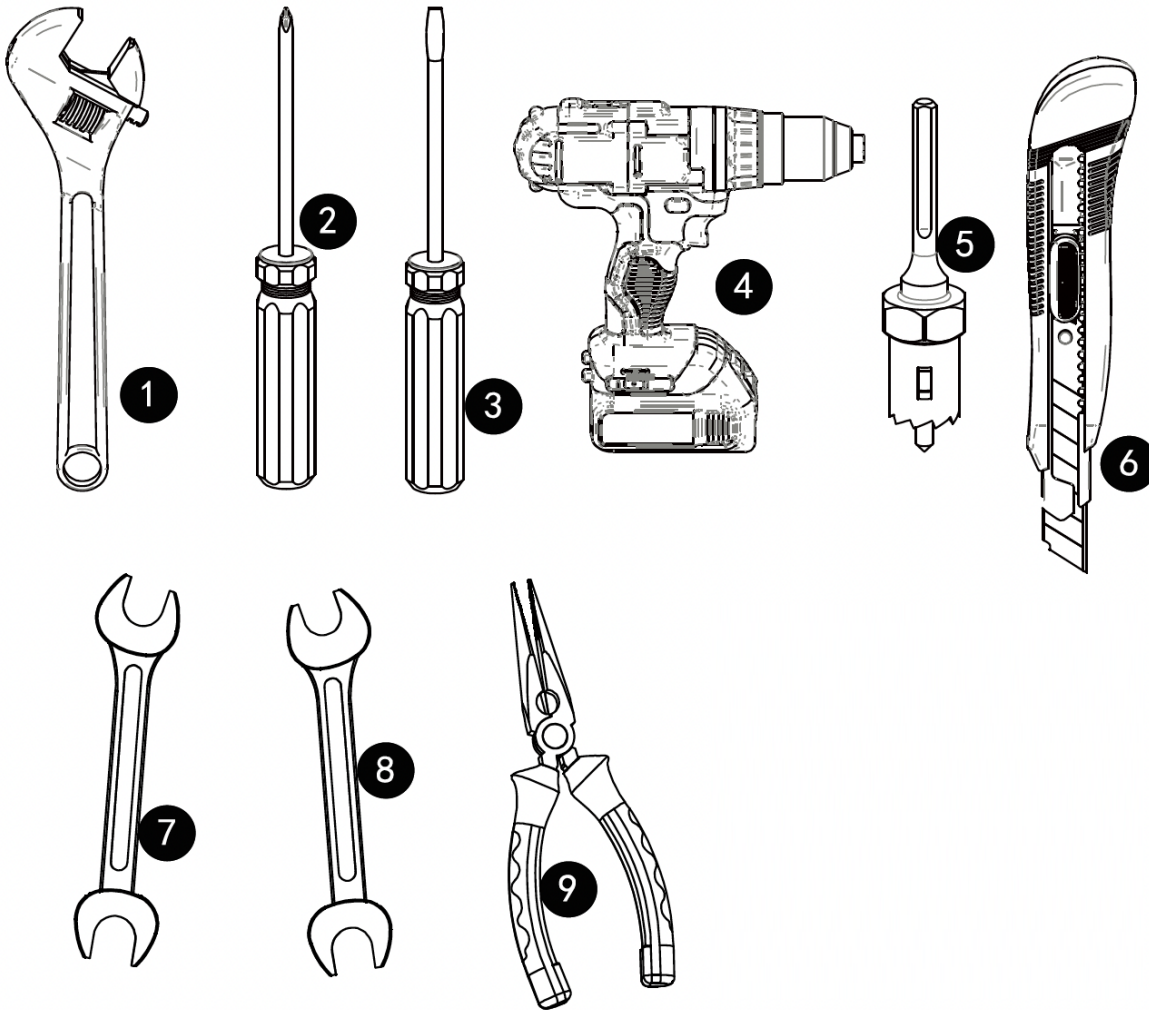

## RECOMMENDED TOOLS FOR INSTALLATION

- |                         |                   |                     |
|-------------------------|-------------------|---------------------|
| 1. Adjustable Wrenches  | 4. Electric Drill | 7. Wrenches 14-16mm |
| 2. Phillips Screwdriver | 5. Hole Saw       | 8. Wrenches 19-21mm |
| 3. Flathead Screwdriver | 6. Utility Knife  | 9. Long Nose Pliers |

### NOTE

As installations may vary, some extra plumbing connection fittings may be required.

## SYMBOLS FOR TUBING CONNECTION

Please familiarise yourself with symbols on the top of the RO system

Pure: Connect to RO Water Tap.

Inlet: Connect to Feed Water.

Drain: Connect to Drain Water.

Power: Connect to Power Supply.

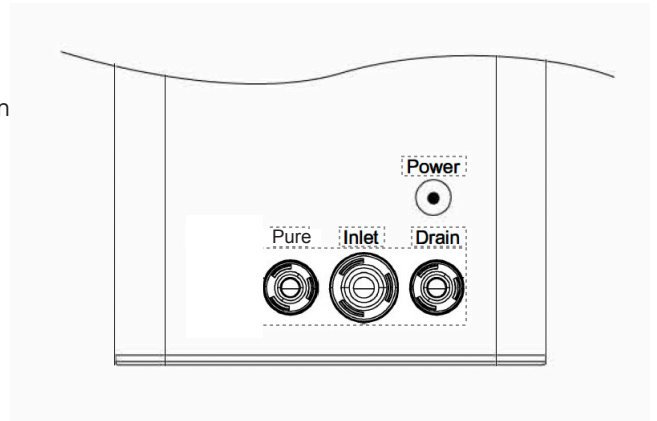

**THE FOLLOWING STEPS WILL ENABLE YOU TO INSTALL THE SYSTEM QUICKLY AND CORRECTLY. SOME VARIATION MAY BE NECESSARY DEPENDING ON THE INSTALLATION.**

### TYPICAL INSTALLATIONS FOLLOW THIS SEQUENCE:

1. Select System Installation Location
2. Tap Installation
3. Install T-Adapter Valve on Water Supply
4. Connect System Drain
5. Install Filter Cartridges

### STEP-1 SELECT SYSTEM INSTALLATION LOCATION

#### IMPORTANT CONSIDERATIONS:

- Access to the bottom (under sink) of the tap is required for attachment of product water line.
- There should be no under sink obstructions which would prevent smooth tubing runs to the inlet, tap, drain connection, or RO module assembly.
- A nearby electrical power socket is required for operation, check the electrical power requirement on transformer.
- The RO system assembly is designed to be installed on counter top or under sink. It should be positioned such that there is access to an inlet water source and drain. The installation should also allow convenient access for servicing.
- Be sure the floor under the RO system is clean, level and strong enough to support the unit.

**STEP-2 TAP INSTALLATION**

The tap is designed to be mounted on the rear lip of the sink. It may be installed in an existing tap hole or in a hole drilled at the time of installation. It may also be mounted to an adjacent counter top. It should be positioned so that water is dispensed over the sink. A 12mm diameter hole is required.

1. Drill a 12mm hole at a proper location on the mounting surface, then take out the tap from the accessory bag, install the tap as the figure 1.
2. Tighten the SS screw and be sure to properly align the tap.
3. Insert the tap adaptor to the bottom of tap.
4. Take out the 1/4" tubing from the accessory bag, cut it to required length, attach one end to the tap adaptor (1/4"), attach the other end to the "Pure" port on RO module assembly, make sure the tubing is fully seated.

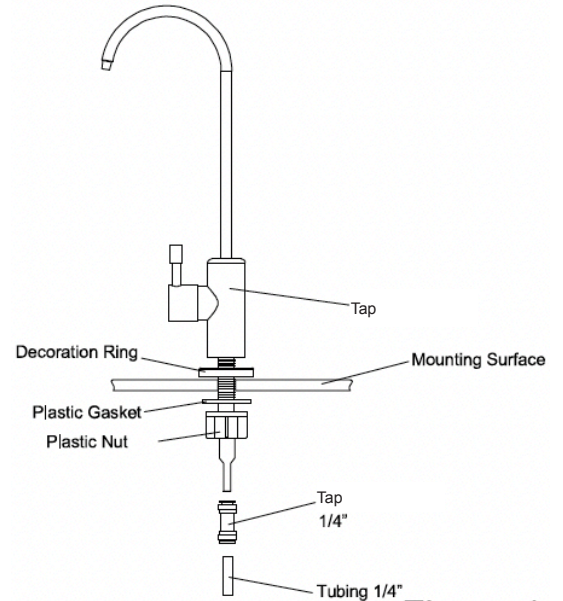
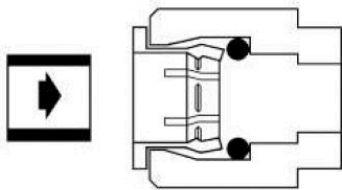
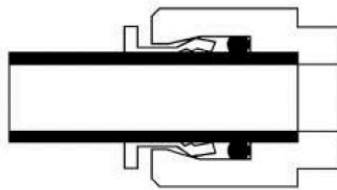

Figure 1

**THE RO SYSTEM FEATURES RELIABLE AND CONVENIENT PUSH-TO-CONNECT TUBING CONNECTORS. TUBING IS EASILY CONNECTED AND DISCONNECTED FROM THESE FITTINGS AS FOLLOWS.**



1. Simply push in tube to attach.



2. Tube is securely in position.

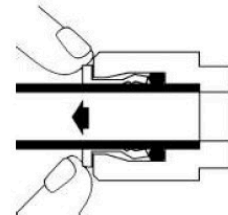

3. Push in collet from both sides to release tubing.

**NOTE**

Do not miss the blue locking clip for all tubing connections.

**CONNECTING:**

Cut the tubing squarely with a sharp knife. Be careful not to crush the tubing. To avoid leaks, make sure the tubing end is smooth and free of burrs and abrasions. Lubricate the end of the tube with water or a light coat of silicone and push the tube end firmly into the fitting. You should feel it push past the O-ring. Avoid bending the tubing sharply away from the fitting.

**DISCONNECTING:**

Hold the collar against the fitting body and pull the tube from the fitting. In the unlikely event that the connection leaks, remove and recut the tubing. Check the inside of the fitting for debris or O-ring damage. Reconnect. Push-to-connect tubing connectors grip the outside diameter of the tube. To help assure a reliable connection, it is important to use high quality tubing with a consistent outside diameter.

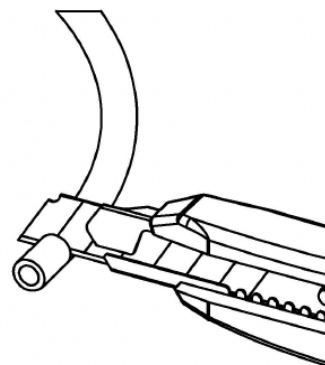

**STEP-3 INSTALL T-ADAPTER VALVE**

1. Turn off the water supply, disconnect the existing pipe. Take the inlet 3-way valve out from the accessory bag, install it on the pipe line as the Figure 2. Note: Additional pipework adjustments may be required.
2. Take out the 3/8" tubing from the accessory bag, cut it to proper length, attach one end to the inlet 3-way valve, attach the another end to the "Inlet" port on RO module assembly, make sure the tubings are fully seated.

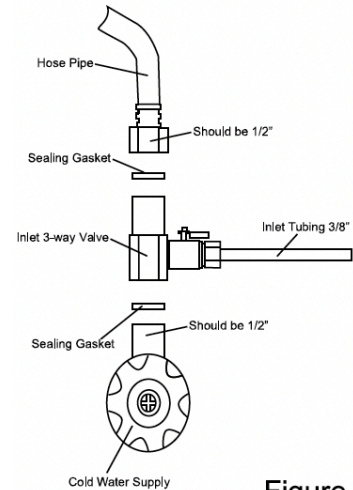

Figure 2

**STEP-4 CONNECT DRAIN SADDLE VALVE**

1. Take out the 1/4" tubing from the accessory bag, cut it to required length, attach one end to the "Drain" port on RO module assembly and attach the another end to the drain pipe line (Figure 3). Make sure the tubings are fully seated.

Ensure the drain saddle clamp is connected above the U-bend.

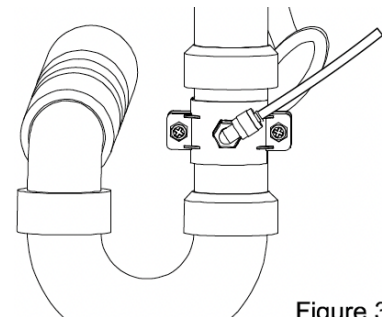
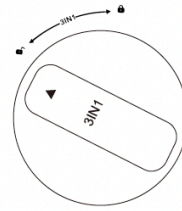

Figure 3

**NOTE** The installation figures above are only for reference, it may vary from different installation sites and conditions.

## STEP-5 INSTALL FILTER CARTRIDGES

1. Take out the filter cartridges from the box.
2. Insert the 3-in-1 Cartridge Z1-C in upper hole, the triangle icon on top of filter element should be pointed at the lock icon (Figure 4).
3. Gently press the filter element and rotate it 90° clockwise, ensure the triangle icon on top of filter element point at lock icon (Figure 5).
4. Follow step 2 and 3 to install the RO filter cartridge (Z1-M).



**Figure 4**

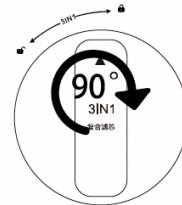

**Figure 5**

**STEP-6 START-UP INSTRUCTIONS**

1. Check system to verify all components are correctly installed.
2. Open inlet valve, connect to water supply.
3. Plug in power cord, connect power on.
4. Open the tap and let the water flow through each filter elements.
5. Flush the filter elements for around 10 minutes. It is normal to see black carbon fines in water.
6. Check system thoroughly for leaks. If any are found, shut off both inlet and power, then correct the issue.
7. After flushing process, close the tap to make sure the boost pump stops working.
8. Reset the filter elements life following the instructions on Page 17.
9. When all the above is done correctly, your RO system is ready to use.

<p><b>⚠ CAUTION</b></p>	<p>Do not drink water produced by the system until the Start-Up procedure has been followed completely!</p>
-------------------------	---

**LED DISPLAY & TOUCH KEYS PROGRAMMING GUIDE**

As the power is on, all lights will flash 3 times (blue-red-blue) along with one beep sound. If no error is found, then the system will automatically flush itself for 30 seconds.

At standby status, light "3 in 1", "RO" and "Error" will automatically light off if no key is operated for 1 minute.

**"Select" Key Used For:**

1. Select the desired filter element to reset filter life.
2. Press and hold "Select" and "Reset" key for 3 seconds to have an automatic forced rinse.

**"Reset" Key Used For:**

1. Press and hold "Reset" key for 3 seconds to enter Filter Life Reset programming.
2. Touch "Select" key to select the desired filter element that need to reset life. Press and hold "Reset" key for 3 seconds, filter life is reset.

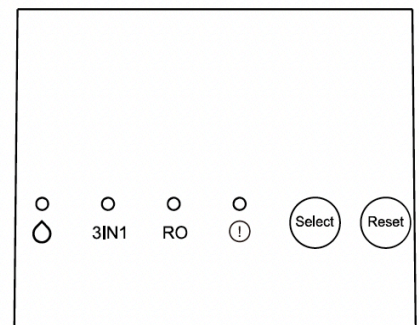

## FILTER LIFE INDICATION:

The filters' life is indicated by 3 in 1 light and RO light. The two lights will display blue colour as the system is newly installed. As more water being treated, the filter become exhausted and need to be replaced. At this time, the light will display red colour. But the system still can work and will not stop the pump.

After the filter is replaced and filter life is reset, the filters' lights will be display back to blue colour again. This means filter's life has been reset.

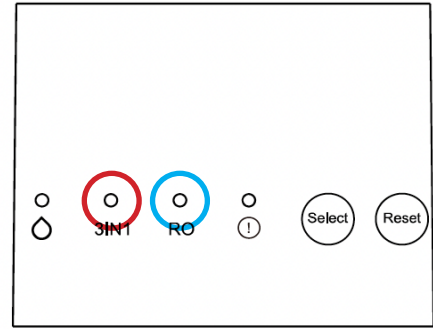

## TYPES OF FILTER ELEMENT FLUSH:

1. Power on: RO system will automatically have a rinse for 30 seconds when the power is supplied.
2. Forced: Press and hold "Select" and "Reset" key for 3 seconds, RO system will automatically have a rinse for 18 seconds. Press "Select" and "Reset" key again will stop the rinse.
3. After Producing Water: If the system produces water > 1 hour and no flushing happened during this time, after the tap is closed, it will automatically rinse for 18 seconds. The system will automatically reset the countdown for 1 hour is any flushing process happened.
4. Standby: If the system continuous standby duration reaches 24 hours and no rinse happens, the system will automatically rinse for 18 seconds.

## HOW TO RESET FILTER ELEMENTS LIFE

1. Press and hold "Reset" key for 3 seconds to enter Filter Element Reset program.
2. Touch "Select" key to choose the filter element you are ready to reset life.
3. Press and hold "Reset" key for 3 seconds, after that you will hear a beep sound twice, that means the filter element life is reset successfully.

### NOTE

In the process of filter reset, if no key is operated for 10 seconds, system will exit Filter Element Reset program.

**SERVICE SCHEDULE**

To keep the RO system operating properly, it is necessary to change the filter elements periodically. Typically, this should be done on an annual basis. Service frequency may vary depending on local water conditions. High sediment, chlorine, turbidity, or hardness levels may require more frequent service.

**USE THE FOLLOWING AS A GUIDE:**

FILTER ELEMENTS	SERVICE SCHEDULE
Z1-C	6 - 12 months
Z1-M	12 - 24 months

Note: Filter life may vary greatly depending on different water quality, RO filter life will be affected by other factors. The service schedule above is only for reference.

**NOTE**

In the process of filter reset, if no key is operated for 10 seconds, system will exit Filter Element Reset program.

**FILTER ELEMENT SHOULD BE REPLACED IF FOLLOWING SITUATIONS OCCUR:**

1. Produced water quality is poor, and has bad taste.
2. Pure water flowrate decreases dramatically, 3 in 1 filter or RO membrane may blind. (Make sure it is not caused by cold water temperature)
3. Filters are heavily blinded, with almost no water produced.

**HOW TO REPLACE FILTER ELEMENTS**

1. Close the 3-way T-adaptor valve to shut off water supply.
2. Open the tap to release pressure.
3. Turn off power supply.
4. Rotate the old filter element for 90° anti-clockwise quickly, as the triangle icon on top of filter element is pointed at lock icon, take out the old element (As Figure 6).
5. Insert the new filter element into the correct hole of filter manifold, the triangle icon on top of filter element should be pointed at the lock icon.
6. Gently press the filter element and rotate it 90° clockwise, ensure the triangle icon on top of filter element is pointed at lock icon (As Figure 7).
7. Turn on the water supply.
8. Turn on the power supply.
9. Follow the instructions on Page 17 to reset filter element life.
10. Flush the new installed filters for 5 - 10 minutes.
11. Filter element replacement complete.

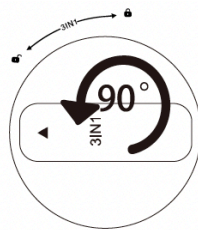
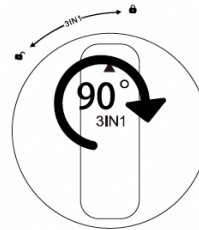
**Figure 6****Figure 7****CAUTION**

Always follow the steps below prior to replacing the filters.

1. Shut off water supply. →
2. Open the tap. →
3. Turn off power supply.

**APPLICATION NOTES:**

1. Pure water flowrate is variable and can be effected by water temperature and pressure. The pure water flowrate stated in the performance data sheet is tested at standard conditions.
2. Disposal of Replaced Filter Element: The replaced filters can not be recycled and reused, it is recommended to discard it as household rubbish.
3. When you are on holiday or not using the system for a long time, please close the T-adaptor valve and turn off power supply.
4. If any of the following occurs, please shut off the water supply and power supply immediately and fix the issue.
  - 4.1 Leakage is found somewhere.
  - 4.2 System's component is malfunctioning.
  - 4.3 Electric leakage is found somewhere.
  - 4.4 Any other abnormal situation or fault.

**PROBLEM****POSSIBLE SOLUTIONS****1. PUMP NOT RUNNING, NO PRODUCT WATER**

- A. Power supply is not on.
- B. Transformer is damaged.
- C. Filter element life expired.
- D. Leakage is detected by system.
- E. System continuously produces water for 60 minutes.
- F. Low incoming water pressure.
- G. Low pressure switch is malfunctioning, power is not switched on to pump.
- H. High pressure switch is malfunctioning and not reset itself.
- I. Pump is damaged.

- A. Plug in the power supply or wait for power to restore.
- B. Replace the transformer.
- C. Replace filter element.
- D. Check the leak and fix it.
- E. Unplug the power and replug it.
- F. Increase incoming water pressure to allow low pressure to switch on.
- G. Repair low pressure switch or replace it.
- H. Repair high pressure switch or replace it.
- I. Replace the pump.

**2. PUMP CONTINUOUSLY RUNNING**

- A. Pump is malfunctioning.
- B. High pressure switch is malfunctioning.

- A. Replace the pump.
- B. Repair high pressure switch or replace it.

**3. PUMP CONTINUOUSLY ON & OFF**

- A. Low incoming water pressure.
- B. Low pressure switch is malfunctioning.
- C. High pressure switch is malfunctioning.
- D. Leakage happens somewhere in system.

- A. Increase incoming water pressure.
- B. Repair low pressure switch or replace it.
- C. Repair high pressure switch or replace it.
- D. Find the leakage and fix it.

**4. NOT ENOUGH PRODUCT WATER**

- A. Feed water valve is plugged or closed.
- B. Sediment/Carbon prefilter (Z1-C) is blocked.
- C. Low incoming water pressure.
- D. Reverse Osmosis Membrane Z1-M is fouled.
- E. The Tap is out of adjustment or faulty.
- F. No water to drain. Drain Flow Restrictor is clogged.

- A. Open valve or unclog.
- B. Replace filters.
- C. Increase incoming water pressure.
- D. Make sure incoming water pressure is within operating limits. Make sure drain line is not blocked. Correct cause of fouling and replace RO Membrane.
- E. Repair or replace tap.
- F. Replace flush solenoid valve.

**5. PRODUCT WATER IS HIGH IN TDS**

- A. Clogged Prefilter (Z1-C).
- B. Reverse Osmosis Membrane Z1-M is expended.
- C. Product water and drain water lines are reversed.
- D. No water to drain. Drain Flow Restrictor is clogged.
- E. New Carbon Postfilter has not been rinsed completely.
- F. The incoming feed water TDS has increased.

- A. Replace Filter.
- B. If Membrane life is unusually short, find and correct the problem. Replace RO Membrane.
- C. Correct plumbing.
- D. Replace flush solenoid valve.
- E. Open the tap and flush the post carbon filter for 10 minutes.
- F. An increase in feed water TDS will also give an increase in Product Water TDS.

**6. TASTES AND ODOURS IN PRODUCT WATER**

- A. Carbon Post Filter is exhausted.
- B. Product water and Drain water lines are reversed.
- C. Increase in Product Water TDS.

- A. Replace Post Carbon Filter.
- B. Correct plumbing.
- C. Replace RO Membrane.

**7. TAP LEAKS OR DRIPS**

- A. Water leaks from tap.

- A. Repair or replace the tap.

**8. EXTERNAL LEAKAGE ON CONNECTION**

- A. Tubing not fully seated in fitting.
- B. Tubing abraded in seal area.
- C. O-rings seal aging.

- A. Check all fittings for tightness.
- B. Recut tubing and redo connection.
- C. Replace the O-rings.





**SPECTRUM UK**

20/20 Business Park, Maidstone  
Kent, ME16 0LS, UK

**Tel:** +44 (800) 368 9302

**SPECTRUM EU**

ul. Maratońska 104a,  
94-102, Łódź, Poland

**Tel:** +48 (42) 881 34 00

**Email:** [techsupport@spectrum-filtration.com](mailto:techsupport@spectrum-filtration.com) **Website:** [www.spectrum-filtration.com](http://www.spectrum-filtration.com)



**SPECTRUM**